



CLINCH STUD **Strux**

STRUX®

OUTPERFORMING EVERY OTHER DRIVE SYSTEM.

Our high-performance STRUX® fasteners offer a stronger and more reliable assembly alternative to traditional clinch studs and nuts. Along with stud and nut applications, the STRUX® design can be applied to joints that require self-tapping fasteners. In most cases, a STRUX® fastening solution will yield significant time and cost savings when compared to welded or other staked fasteners.



FEATURES

- ▶ Heat treated to SAE grades, ISO classes or to your own specifications
- ▶ Displacement lobes
- ▶ Can be used where welding is impossible or undesirable, such as joining dissimilar materials, pre-coated sheets or high strength thin sheet materials
- ▶ Unlike spot welding, joints can be created in-die with clinch fasteners and automated installation equipment
- ▶ Can be installed after the painting or coating process without aesthetic damage barrier for displaced material
- ▶ Easy installation and simple visual inspection

BENEFITS

- ▶ Fast and easy installation
- ▶ Simple tooling
- ▶ High torsional resistance
- ▶ High Push out resistance
- ▶ Consistent performance
- ▶ Can be installed in stamping die
- ▶ Improved positional tolerances as compared to weld studs and nuts.
- ▶ Eliminates the assembly problems and high cost traditionally associated with weld fasteners
 - ▶ Weld Splatter
 - ▶ Excessive heat

VARIATIONS

- ▶ Strux® Nut
- ▶ Strux SM
- ▶ Struxtite®Nuts
- ▶ Prevalok™





CONVERTING TO STRUX® OFFERS SAVINGS

Acument Global Technologies has developed a line of products to meet the increasing demand for thin sheet steel and aluminum sheet applications. Our Strux® line of clinch fasteners provides an external or internal thread in sheet metal applications too thin to ensure adequate thread engagement using screws or bolts and in situations where welding is impossible or undesirable.

Strux® Clinch Studs - External Threads

- Cost-effective, high performance alternative to other staked or welded products

Strux® Clinch Nuts - Internal Threads

- A unique configuration offers unmatched product strength and reliability when compared to competitive products

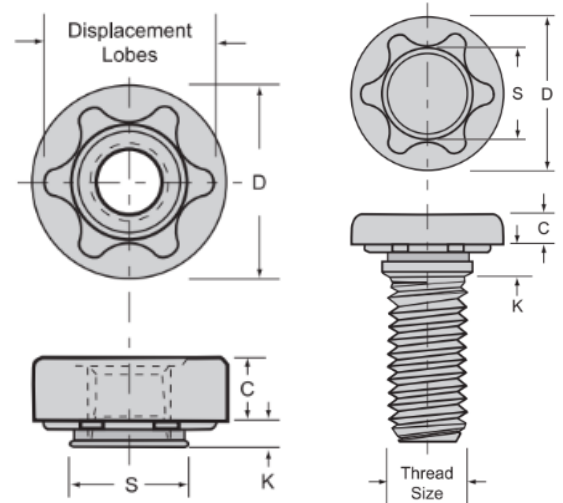

INSTALLATION OF STRUX® STUDS AND NUTS

Strux® Clinch Studs

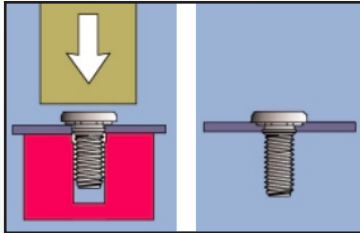

The stud end is fed through a punched or drilled hole and into a lower die. A punch then applies force to the stud. As this occurs, the retaining ring passes through the hole. As pressure is applied, the displacement lobes are seated, forcing the engagement material into the retaining groove.

Strux® Clinch Nuts

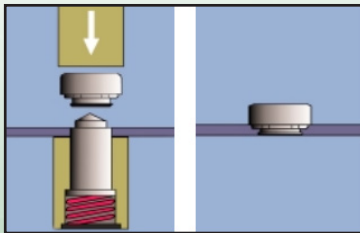

Installation of the STRUX® nut is essentially the same as the STRUX® stud. The retaining ring passes through the hole and as the displacement lobes seat, the engagement material flows into the retaining groove. However, the nut is supported by a spring loaded pin to ensure proper nut alignment. As the nut is staked, the pin retracts.